

Aesculap® Targon® PFT

Intramedullary Nail For Proximal Femoral Fractures



Aesculap Orthopaedics

Aesculap® Targon® PFT



Hans-Werner Stedtfeld, MD
Formerly: Centre for Trauma
Surgery, Nuremberg, Germany

Dear colleagues,

For 10 years now, the clinical results of treating the various types of trochanteric fractures with the Targon® PF have been excellent.

These results have been published and presented in numerous countries. Complication rates have sometimes been sensationally low. The enhanced telescopic property inherent in this combination of a lag screw with a nail has proven its worth. This is manifested by a very low cut-out rate. System performance has also profited from having medialized the telescoping action, since this avoids secondary protrusion of the implant into the peritrochanteric soft tissue. This occurs regularly with other systems during impaction of the fractured bone and quite often results in revision surgery. Nevertheless, there were indications for further improvement of the system with even better reduction of the complication rate. This development has resulted in the present Targon® PFT system.

The most important modification, which is also reflected by the new name of the system, has been to merge both sleeve and lag screw into what is known as the 'TeleScrew' (T).

This virtually rules out any uncontrolled proximal migration, which might take place if the sleeve is too short (an extremely rare complication to date).

The new thread of the lag screw represents yet another significant modification. As has been demonstrated in experimental models, this enables a better grip even in osteoporitic bone, while at the same time lowering the risk of penetration (for instance, as in cut-out).

Another major improvement has been to simplify and color-code the instruments. A patented adapter system permits mounting of the targeting device irrespective of the CCD angle: there is just one targeting device for all angles.

These then are the most important but by no means the only modifications. The Targon® PF-Nail, of course, still retains all of its present essential features.

January, 2011

...because
two
are better
than one

Aesculap® Targon® PFT

System Advantages Implants

TeleScrew

Dynamic sliding action through telescoping cantilever

A



Linked lag screw in the sleeve

- More efficient implantation

Expanded maximum sliding range

- Deeper manual extension of the TeleScrew for enhanced subcortical placement of the screw

Optimized lag screw thread

- Pan-head screw with a cylindrical core
- Rounded cutting edges, self-tapping both for insertion and removal
- Prevents perforation of the screw
- Larger contact zone with the bone
- Better fixation of the screw in the osteoporotic bone
- Less cut-out of the thread
- Deeper manual screwing of the TeleScrew spares the interface

Integrated distraction stop

- Stops the lag screw from migrating proximally



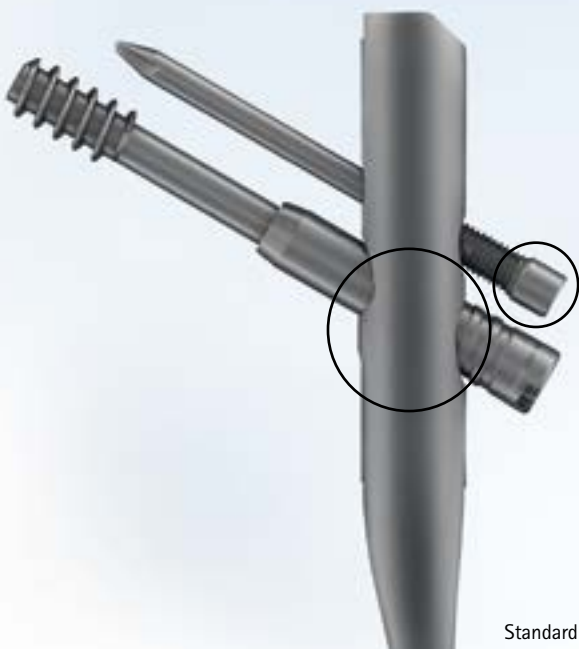

Standard nail

Antirootation Pin

Biaxial stabilization of the fracture without the risk of rotation

Antirootation pin with lateral reinforcement

- Increased stability of the implant
- Less risk during removal

Standard Nail

Nail with proximal reinforcement

- Less risk of fracture at the zone with the highest loading

Better elasticity through longitudinal slots

- Less risk of fracture at the nail boundary

Reinforced design of the distal sleeve

- Longer and more flattened thread
- Increased stability of the composite system

Longer lag screw guidance in the sleeve

- Improved telescoping action
- Reduced risk of jamming



Aesculap® Targon® PFT

System Advantages Implants

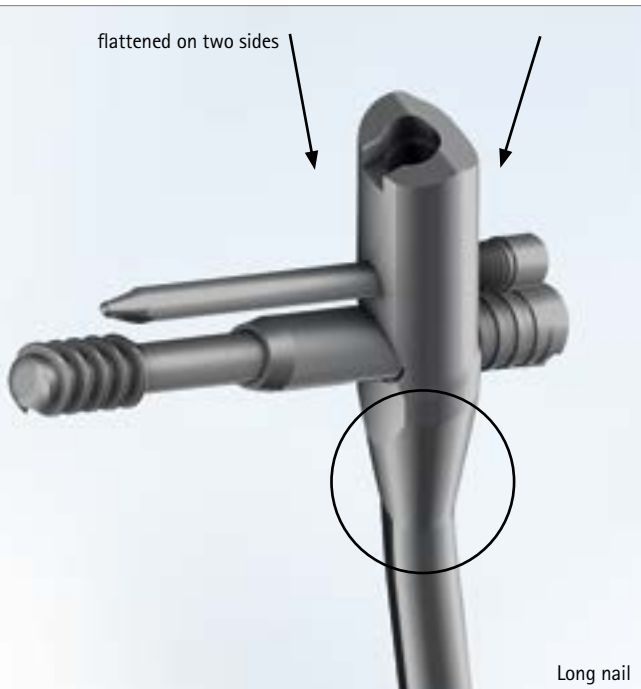

Long Nail

Cannulated for easier passage of the nail across the fracture zone

Long nail with thicker wall for pathologic fractures

Short Nail

Nail length 175 mm

■ Implant best compatible with small skeletal systems

System Advantages Instruments

B

Graduated Drill Bit

Self-centering graduated drill bit

- Less operating steps

Depth stop for graduated drill bit in the nail

- Safe drilling to the predefined length of the TeleScrew

Torque Screwdriver

Preset torque during insertion of both TeleScrew and antirotation pin

- Prevents excessive jamming of the implants
- Facilitates implant removal



Aesculap® Targon® PFT

System Advantages Instruments

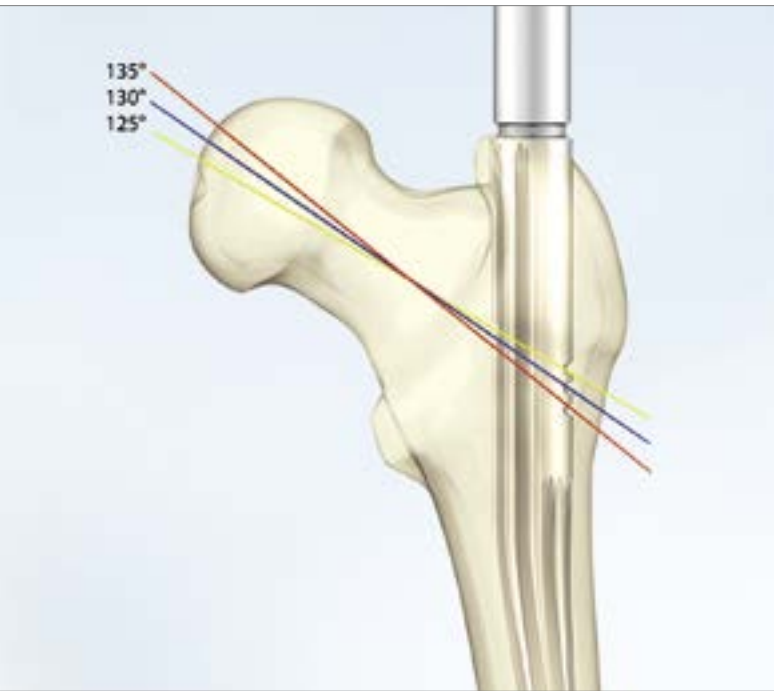

Contoured Reamer

Radiopaque marking on the contoured reamer

- Facilitates intraoperative assessment of the neck shaft (CCD) angle
- Helps precise positioning of the TeleScrew

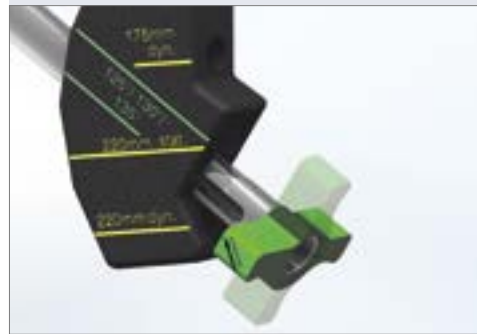

New targeting device

- Enhanced geometry of the bow permits smaller incisions and thus less invasive procedures
- More space in obese patients
- Guide pin assists in the correct intraoperative alignment of the nail

New patented attachment of the targeting device with the nail

- No angle attachments required
- Better accuracy of the targeting device
- Easier handling
- Shorter operating time

New patented locked seating of the drill bushings in the targeting device

- Slight rotation seats the polygon profile of the bushings in the targeting device
- Quick and easy attachment of the sleeve

Aesculap® Targon® PFT

Biomechanics

C

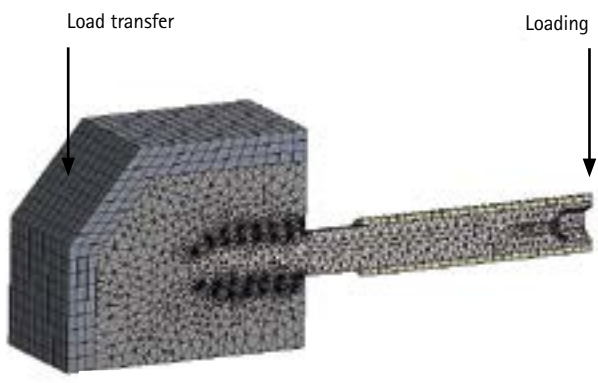

Method

Targon® PF and Targon® PFT comparison

- Finite element calculation for assessment of the surface stress present at the lag screw in a virtual bone-implant system

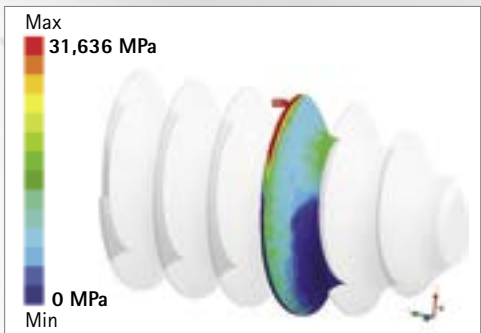

Distribution of stress along the thread flank – previous lag screw design

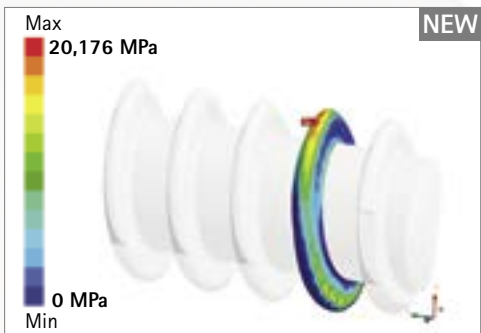

Reduced stress peaks along the thread flank – enhanced Targon® PFT lag screw

- Result: less surface stress and therefore less loading of the simulated cancellous bone

Result

Targon® PF and Targon® PFT comparison

- Dynamic cut-out / penetration test of the lag screw with simulated osteoporotic cancellous bone (polyurethane foam of given density, experimental setup similar to the finite element model on the left)
- Sum of all load cycles run with the various foam samples until failure (cut-out or penetration)
- Result: longer life-span and less failure for the Targon® PFT lag screws

20 % improvement

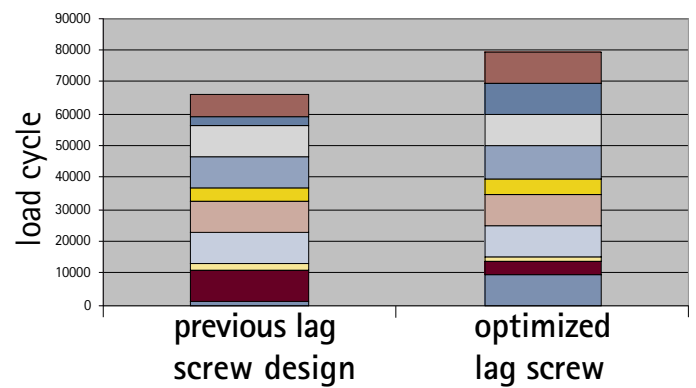

Result

Targon® PF and Targon® PFT comparison

- Less contact stress along the thread of the lag screw
- Better fixation of the screw in osteoporotic bone
- Longer life-span of the implant-bone interface

Aesculap® Targon® PFT

The Implant

D

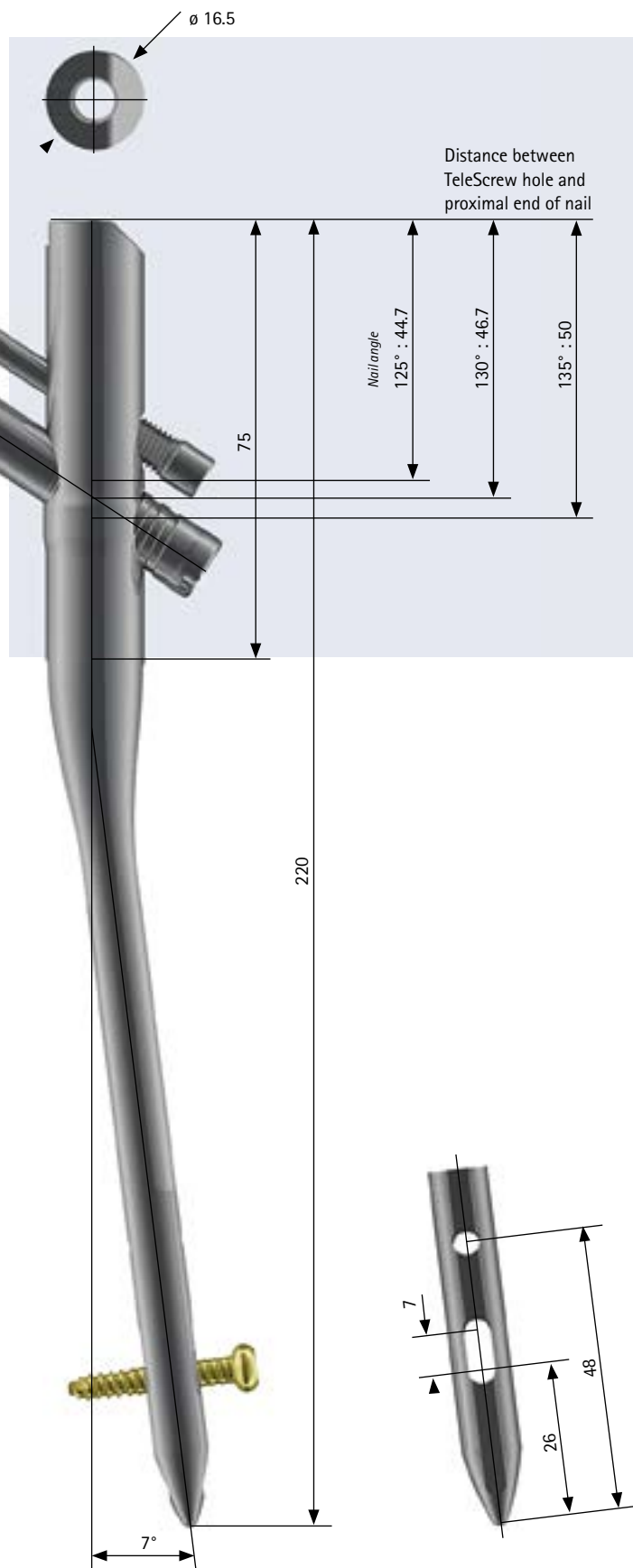

Standard Nail Specifications

- Proximal diameter: 16.5 mm
- Reinforced wall thickness around the TeleScrew: 0.5 mm
- Distal diameter: 10 and 12 mm
- Length: 220 mm
- CCD angle: 125°, 130°, 135°
- Length of proximal end: 75 mm
- Valgus angle: 7°
- Thread for nail connection: M8
- Distance TeleScrew / proximal end of nail:
 - Nail angle 125°: 44.7 mm
 - Nail angle 130°: 46.7 mm
 - Nail angle 135°: 50 mm

Implant material:
Titanium alloy Ti6Al4V
Anodized surface

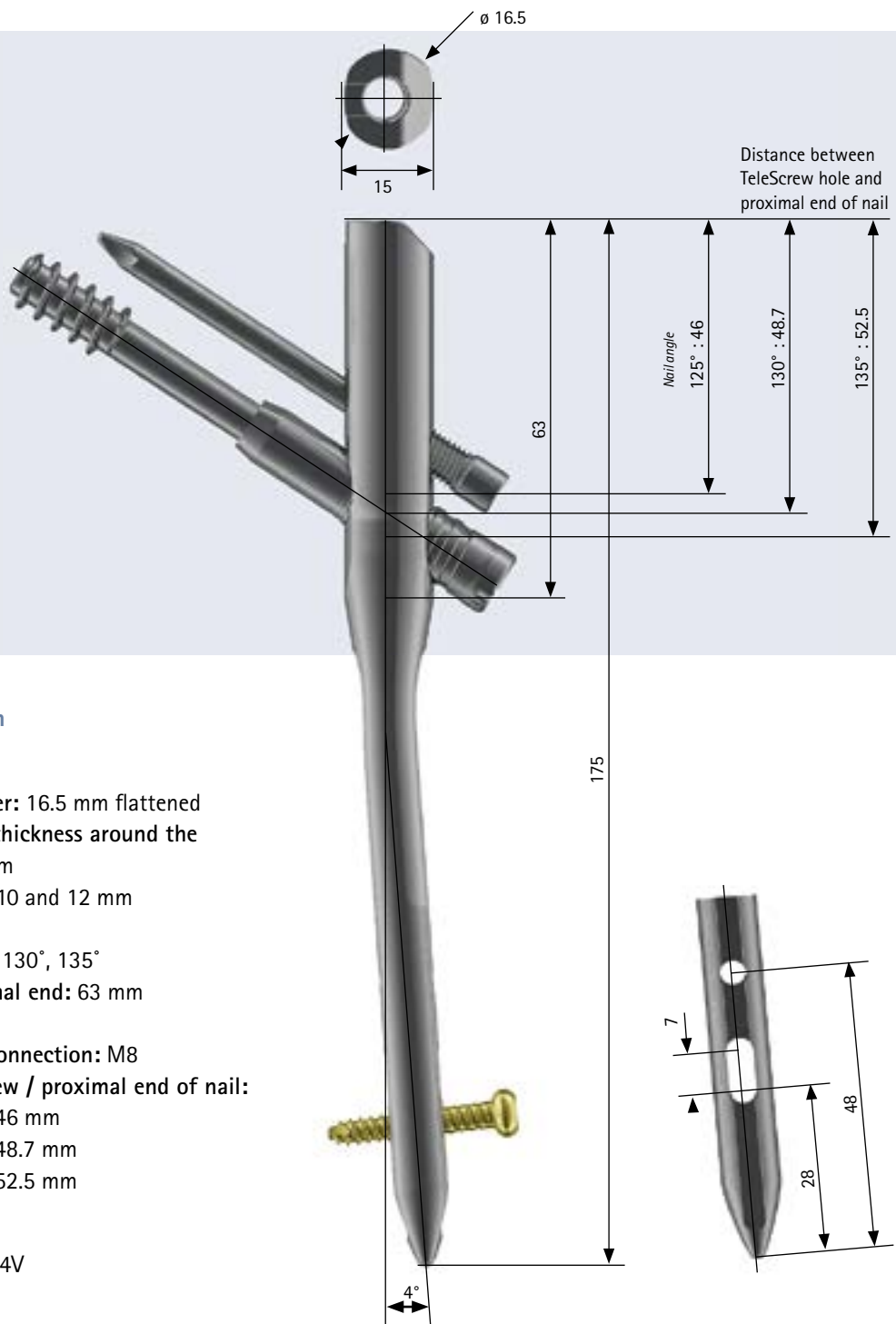

Short Nail 175 mm

Specifications

- Proximal diameter: 16.5 mm flattened
- Reinforced wall thickness around the TeleScrew: 0.5 mm
- Distal diameter: 10 and 12 mm
- Length: 175 mm
- CCD angle: 125°, 130°, 135°
- Length of proximal end: 63 mm
- Valgus angle: 4°
- Thread for nail connection: M8
- Distance TeleScrew / proximal end of nail:
 - Nail angle 125°: 46 mm
 - Nail angle 130°: 48.7 mm
 - Nail angle 135°: 52.5 mm

Implant material:
 Titanium alloy Ti6Al4V
 Anodized surface

Aesculap® Targon® PFT



Long Nail Specifications

- Proximal diameter: 16.5 mm flattened
- Reinforced wall thickness around the TeleScrew: 0.5 mm
- Distal diameter: 10 and 12 mm
- Length: 260 till 460 mm (in 40 mm steps)
- Angle: 125° (D 10 + 12 mm)
130° (D 12 mm)
- Length of proximal end: 64 mm
- Anteversion TeleScrew: 10°
- Valgus angle: 4°
- Thread for nail connection: M8
- Antecurvature: 1500 mm
- Cannulated: 4 mm
- Distance TeleScrew / proximal end of nail:
Nail angle 125°: 45.8 mm
Nail angle 130°: 47.7 mm

Implant material:
Titanium alloy Ti6Al4V
Anodized surface

Antirotation Pin

Specifications

- Nominal diameter: 5 mm
- Incremental length: 5 mm
- Size of Allen wrench: 4.5 mm
- Self-tapping



TeleScrew

Specifications

- Thread diameter: 10.4 mm
- Pitch: 3 mm
- Incremental length: 5 mm
- Size of Allen wrench: 4.5 mm and 7 mm
- Self-tapping for insertion and removal

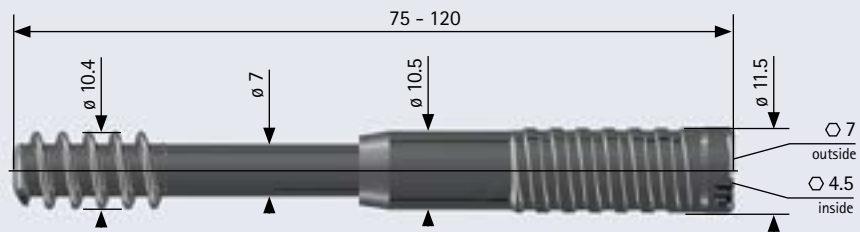

Locking Screw

Specifications

- Thread diameter: 4.5 mm
- Pitch: 1.75 mm
- Incremental length: 4 mm
- Size of Allen wrench: 4.5 mm
- Self-tapping

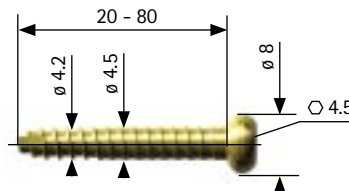

Cap Screw

Specifications

- Thread: M8
- Size of Allen wrench: 4.5 mm

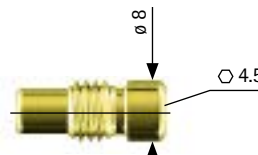

Implant material:

Titanium alloy Ti6Al4V

Anodized surface

Aesculap® Targon® PFT

Indications

E

The Targon® PFT is indicated in:

All trochanteric fractures

- Stable and unstable pertrochanteric (AO / ASIF classification 31-A1, A2)
- Unstable intertrochanteric (reversed fractures, AO / ASIF classification 31-A3)
- Basocervical fractures (AO / ASIF classification 31-B2.1)
- Subtrochanteric fractures according to the Seinsheimer classification
- All of these fractures combined with fractures of the shaft
- Pathological fractures
- Pseudarthroses



Seinsheimer classification

Mono-axial fixation of the femoral neck

If a cranial component can definitely be ruled out in subtrochanteric fractures (type V), then the Targon® PFT could simply be locked at the cervicocephalic position, i.e. mono-axially without the antirotation pin.

Mono-axial locking may also be chosen for stable trochanteric fractures (without the risk of rotation).

In all other cases full dual locking is mandatory.

Fracture Reduction and Locking Options

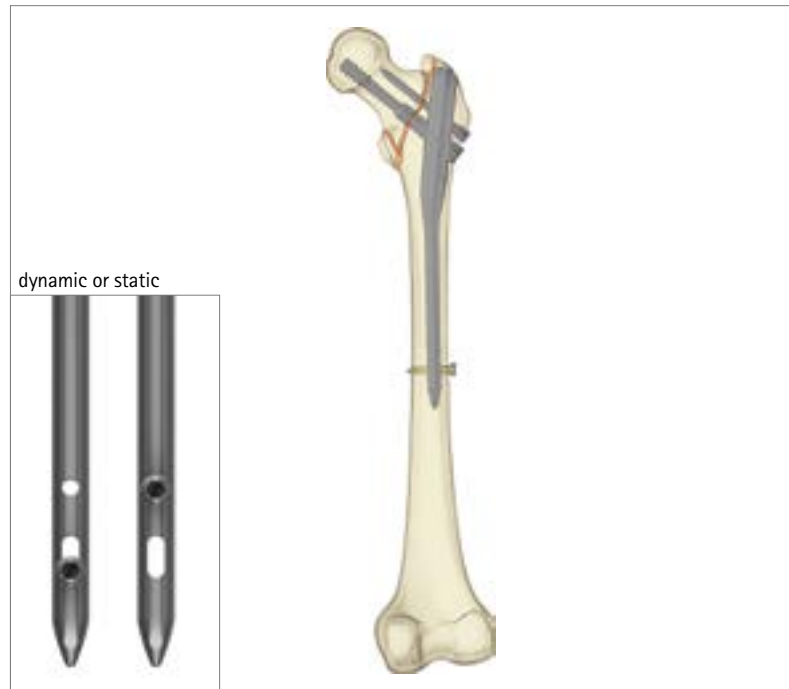

Locking

Distal locking protects the nail against rotation along the longitudinal axis and will be static.

Stable pertrochanteric fractures (AO / ASIF classification 31-A1)

Mono-axial system option

Mono-axial locking may also be performed in stable trochanteric fractures without the risk of rotation.

Unstable intertrochanteric and pertrochanteric fractures (AO classification 31-A2 and A3)

Reduction

Upon extension, complete reduction can be achieved in almost all of these fractures. Profiling the medullary canal with the corer and contoured reamer helps protect the lateral wall of the greater trochanter. The nail will slip into its precise location without any use of force, i.e. definitely without resorting to the mallet. Together with the antirotation pin, the TeleScrew protects the medial fragment from the forces of rotation and bending. The axial compression forces are controlled and cushioned.

Aesculap® Targon® PFT

Fracture Reduction and Locking Options



Locking

Stable fractures require dynamic distal locking.

Locking

In case of stable contact with the fragment, unstable fractures (in particular type IIC, IV and V) should undergo static distal locking.

Subtrochanteric fractures according to the Seinsheimer classification

Reduction

It is better to reduce the dislocation characteristic of this type of fracture (proximal fragment flexed, abducted and externally rotated) on a standard operating table.

Mono-axial system option

Mono-axial locking will suffice in most subtrochanteric fractures. If a cranial component of the fracture can definitely be ruled out (type V), then cervicocephalic locking would simply require the TeleScrew. In all other cases full dual locking is mandatory.



All of these fractures combined with shaft fractures

Fracture type

These may either be extensive pertrochanteric or subtrochanteric fractures or fractures at two or more levels, where one level involves the trochanteric region and the other the femoral shaft.

Type of nail

These fractures may only be treated with the long model of this nail, which will enter the bone at the tip of the greater trochanter since its curvature is slightly less in the mediolateral direction.

Pathological fractures

Most pathologic fractures complicating advanced stages of metastasizing tumors lend themselves only to palliation. With full proximal and triple distal locking, the long 12 mm Targon® PFT is characterized by a high degree of fatigue strength, permitting patients rapid and sustained full weight bearing for the remainder of their lives.

Aesculap® Targon® PFT

Surgical Technique

Preoperative Planning

- KH521 – X-ray template Targon® PFT standard (an example is shown in the Figure)
- KH522 – X-ray template Targon® PFT short
- KH523 – X-ray template Targon® PFT long

The X-ray templates indicate the full size of the implant on the radiogram plus a magnification factor of 10 %. The radiograms for the operation must also be obtained with this magnification factor.

All parameters determined with this template must be verified during surgery in order to ensure that the correct size of the implant is chosen.

If needed, these X-ray templates can also be supplied in digital form.

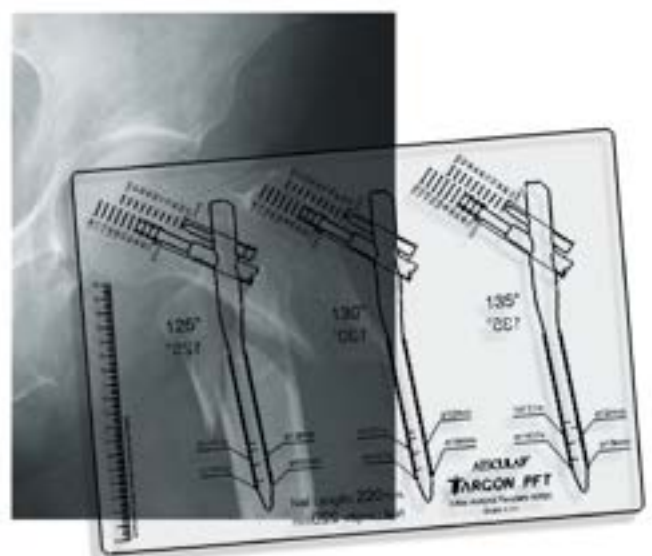
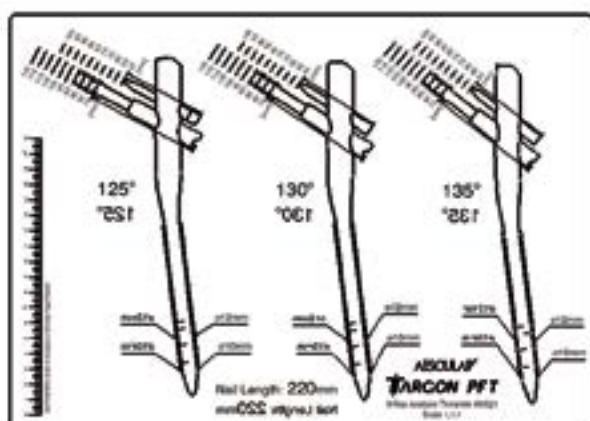

Patient Positioning



A-p fluoroscopy



Axial fluoroscopy



Aesculap® Targon® PFT

Surgical Technique

Approach

1



Fig. 1:
Palpate the tip of the greater trochanter (Fig. 1).

Incise the skin over a distance of about 3-4 cm and split the subcutaneous tissue and fascia lata. If necessary, make a higher incision in the case of obese patients.

In case of doubt, check the position of the incision by fluoroscopy.

Fig. 2:
a. Standard approach and incision
b. Approach in obese patients



Opening up the medullary canal

2

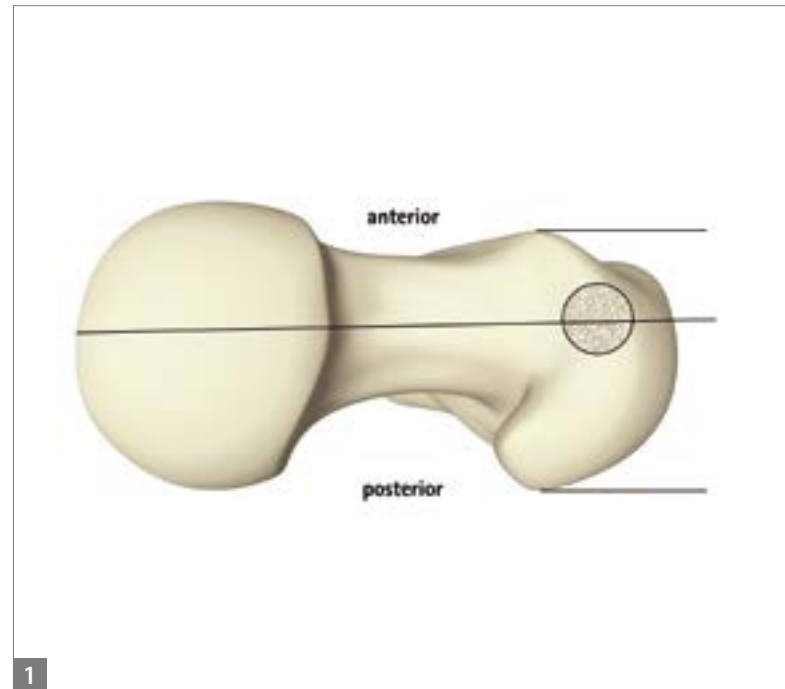

The correct entry portal of the nail is at the tip of the greater trochanter along the center line of the trochanter major (Fig. 1+2).

Long nail:

When working with the long model, the entry point of the guide pin with its stop should be somewhat more medial.



Aesculap® Targon® PFT

Surgical Technique

Option A

Opening Up with the Corer

2.1

- KH525R – Guide pin with stop
- KH319R – Universal handle
(part of intramedullary reaming set GE661)
- KH526R – Tissue protector
- KH458R – Quicklock T-Handle
- KH524R – Corer

Using the universal handle, insert the guide pin with its stop into the greater trochanter either manually or using the drill. Check the position on the fluoroscopy.

Advance the tissue protector with T-handle over the guide pin until it is in contact with the trochanter.

Open up the medullary canal with the corer (either motor-driven or manually).

Then clean any fat from the medullary canal by suction.



Option B

Opening Up with Broach

2.2

- GE663S – Guide pin 2.5 mm
(for cannulated long nail)
- KH458R – Quicklock T-Handle
- KH526R – Tissue protector
- KH527R – Broach

alternatively

- KH668S – Guide pin (for standard nail)
- KH319R – Universal handle
(part of intramedullary reaming set GE661)

Insert guide pin with universal handle in the center of the medullary canal. Advance the tissue protector, slip the broach over the guide pin and drill.



Aesculap® Targon® PFT

Surgical Technique

Preparing the Nail Bed

A – Trochanteric

3.1

- KH528R – Contoured reamer for PFT nail 220 mm
- KH529R – Contoured reamer for PFT nail 175 mm and long nail

Possibly use flexible intramedullary reamer or broach if entry to the medullary canal is narrow.

The radiopaque markings on the reamers for the 135°, 130° and 125° CCD angle facilitate intra-operative determination of the CCD angle (Fig. 1). Due to the difference in implant position, the CCD angle determines the distance of the TeleScrew from the Adams' arch and the positioning of the lag screw in the femoral head. To measure the angle under fluoroscopy, superimpose a guide pin over the marking on the contoured reamer. Advance the contoured reamer distally by up-and-down movement of the handle under slight axial pressure (never use a hammer) until the marking notch has reached the tip of the trochanter.

Fluoroscopy check

For nails with a diameter of more than 10 mm or when the medullary canal is very narrow, the isthmus may be enlarged with a flexible intramedullary reamer.

If the proximal medullary canal is narrow, space can be created with the intramedullary broach KH527R.

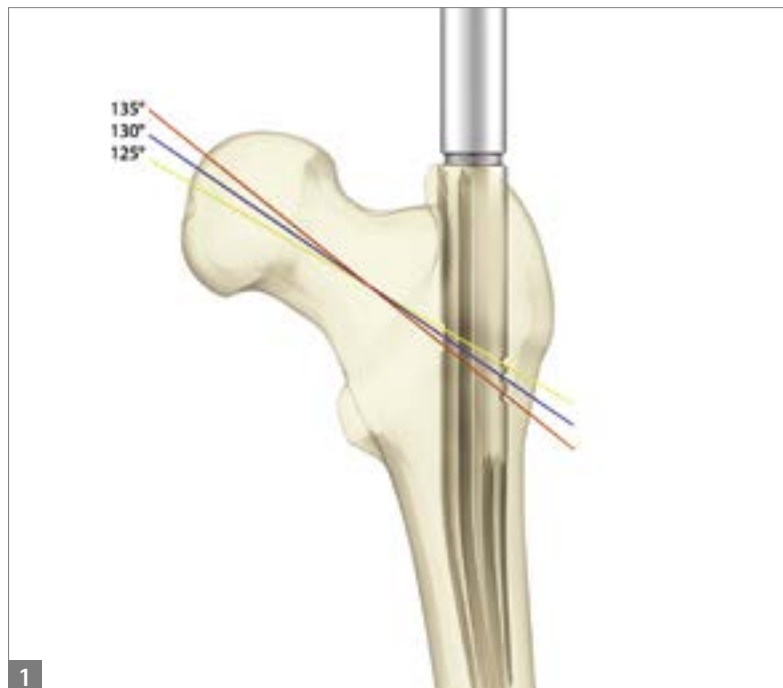

If there is a shift in the bone contour when the contoured reamer is introduced in the Adams' arch, the process must be repeated under increased medial pressure in order to work a depression into the medial fragment for receiving the nail.

B – Shaft area

3.2

- KH463R – Reduction instrument (sharp) (KH464R)
- GE663S – Guide pin 2.5 mm
- KH319R – Universal handle
(part of intramedullary reaming set GE661)
- KH478P – Length gauge
- GE666R – Shaft for intramedullary reamer
(part of intramedullary reaming set GE661)
- GE668R ff. – Intramedullary reaming bits size D9
and up (part of intramedullary reaming set GE661)

Preparing the entry portal acc. to option A or B, with long nails after use of the contoured reamer.

Important:

Do not activate the reamer until below the lesser trochanter to avoid causing excessive weakening of the greater trochanter.



Aesculap® Targon® PFT

Surgical Technique

Mount the reduction instrument on the T-handle, reduce the fragments and advance it along the medullary canal beyond the fracture zone.

Advance the guide pin through the reduction instrument to the desired position of the distal tip of the nail (distal femoral metaphysis).

Make sure that the olive-tipped end (stop for intramedullary reamer) enters first.

Remove the reduction instrument over the guide pin. (Alternatively, the fracture may also be reduced with just the guide pin and the universal handle). Slip the length gauge over the guide pin and advance until it contacts the bone. Make sure to measure from the cortical bone and not to advance the length gauge into the opened up medullary canal.



For reaming of the medullary canal, connect the shaft of the intramedullary reamer with the chosen bit and slip over the guide pin (Fig. 2). Starting with the smallest bit size (9 mm), carefully ream the medullary canal from below the lesser trochanter by a slight feeding action and in diameter increments of 0.5 mm.

The site must be flushed copiously and over-heating with subsequent tissue necrosis is to be avoided. Ream the medullary canal until its diameter is about 1–2 mm larger than the size of the selected nail. Do not activate the reamer over fragment edges or in the area of third fragments or areas of detritus.

Stop the feed at the olive. Do not advance the bit beyond the olive. Possibly check with fluoroscopy.

Insert the nail into the femur over the guide pin and remove the latter through the nail.



Important:

The length of nail needed is read off not from the end of the guide pin but from the laser marking on the pin ('reference to guide pin marking')

Mounting the Nail to the Targeting Device

4

- KH520P – Targeting device
- KH450R – Nail adapter screw
- KH548R – Nail adapter wrench
- KH458R – Quicklock T-handle

Mount the selected implant to the targeting device. Insert the nail adapter screw into the targeting device and tighten to nail using the nail adapter wrench and the Quicklock T-handle.

Long nail model:

Note the different left and right models for long nails.

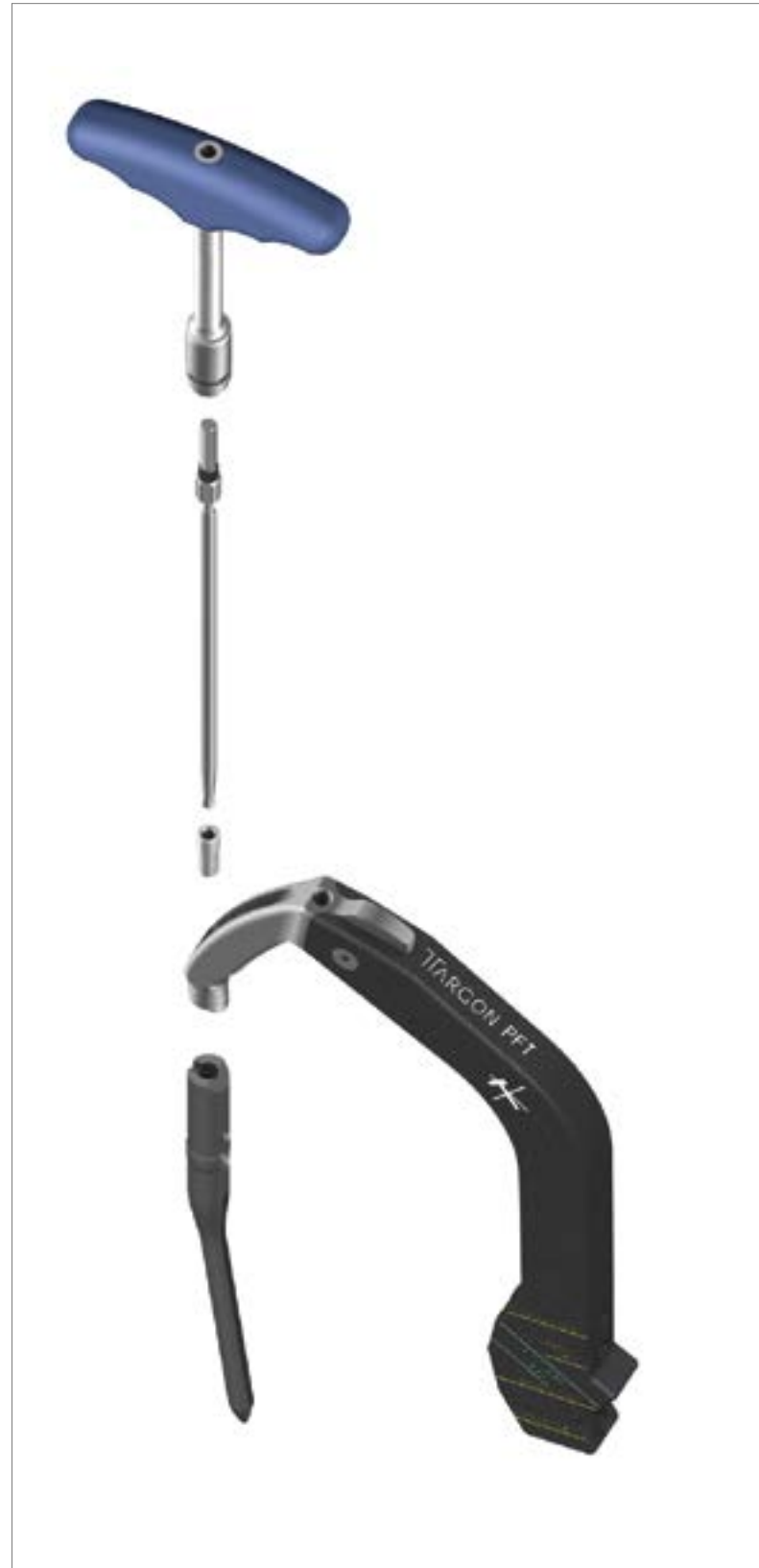

Aesculap® Targon® PFT

Surgical Technique

Inserting the Nail

5

Insert the nail by hand. If the nail must be hammered in (long nail), only hit gently on the bump of the targeting device.

Determining nail depth

The positioning of the nail must be checked by fluoroscopy. Superimpose the guide pin over the soft tissue (drape) in line with the tissue protection sleeve. Under a-p fluoroscopy with the C-arm, the guide pin should lie closer to the Adams' arch and end up centrally in the femoral head (Fig. 2).

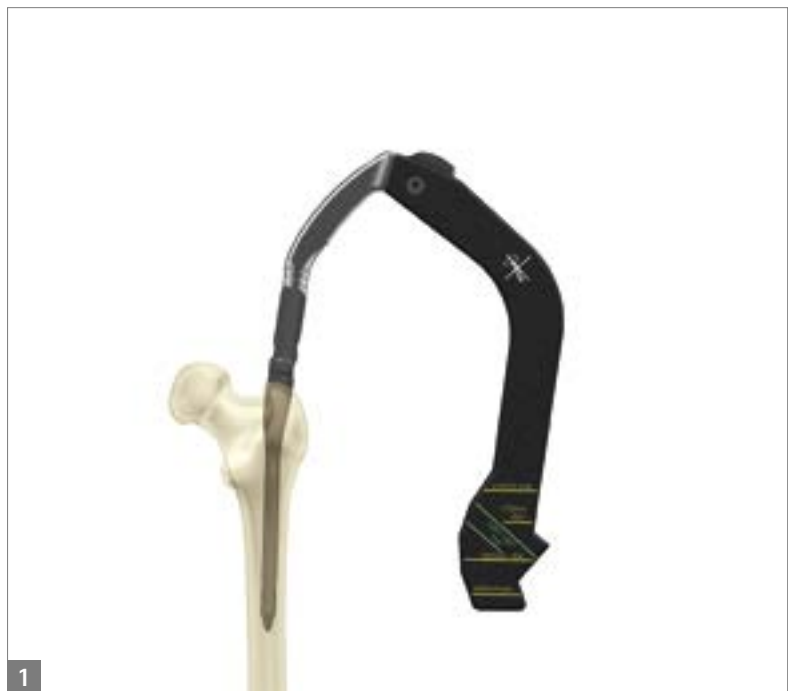

6

Fine Adjustment of the Nail Position



■ KH668S – Guide pin

Advance the tissue protector with the obturator through a small incision in the skin and fascia until it contacts the bone. Note the 'cranial' marking on the tissue protector. Under fluoroscopy determine the correct depth of the nail. If the nail cannot be advanced far enough, it is replaced by the contoured reamer, which is then advanced further distally. Once the correct depth has been reached, the targeting device is swiveled until the correct rotation has been obtained.

Aligning the nail

The anteversion of the nail is checked by inserting the guide pin through the appropriate holes in the targeting device (Fig. 1). When viewed along the axis, the guide pin should lie centrally over the femoral neck (Fig. 2) and be aligned with the center of the femoral head. In the axial beam path, center the C-arm on the common plane of the femoral head and the radiopaque shadow of the metal core of the bow of the targeting device. Swivel the bow until its shadow is within the same plane as the femoral neck and femoral head (Fig. 3).

During the next phases of the procedure, it may be necessary to exert distal pressure on the nail (this



compensates for the slightly cranially-oriented operating steps). This may be done by an assistant exerting pressure with a screwdriver via the impactor attached to the targeting device.

Aesculap® Targon® PFT

Surgical Technique

Opening Up the Lateral Cortical Wall

7

- KH531R – Obturator
- KH532R – Tissue protector large

Make a stab incision, advance the tissue protection sleeve with the obturator turned through 180° until it contacts the cortical bone. Convert point contact into line contact by turning the obturator and lock in the hole of the targeting device by turning (Fig. 1+2).

Note the cranial alignment of the sleeve. Make sure that no soft tissue exerts pressure on the drill sleeve and alters its position. Remove obturator.

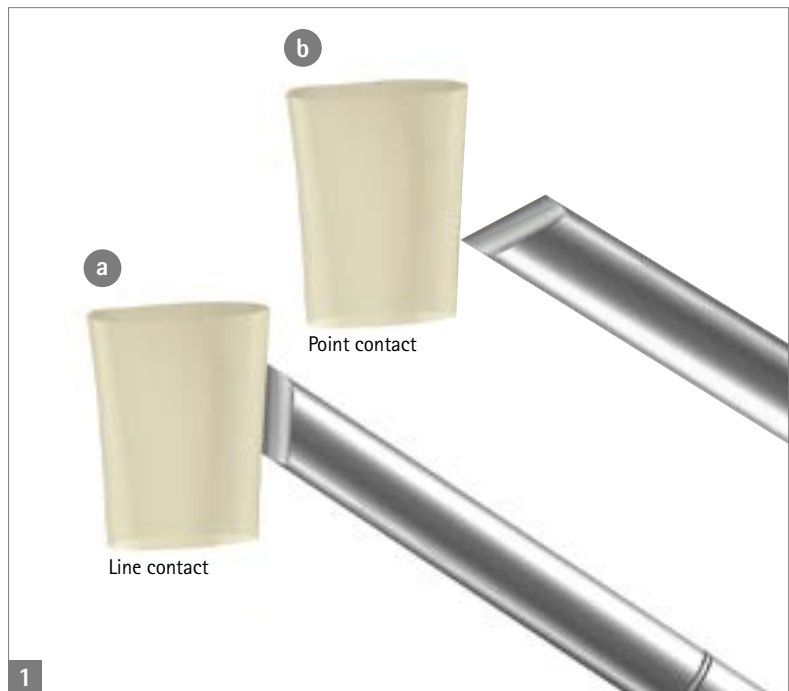

- KH668S – Guide pin \varnothing 3.0 mm
- KH537R – Drill sleeve for guide pin
- KH554R – Cannulated access drill

Insert the sleeve in the tissue protector and advance the guide pin through the bone by high-speed drilling until it reaches the cortical wall of the femoral head.

Optional instrument: Cannulated access drill KH554R

The cannulated access drill KH554R can be used optionally in very hard bone to open up the lateral cortical wall. The access drill is advanced over the guide pin and drilled up to contact with the nail.

Subsequent length measuring as described in chapter 8. Then insert the antirotation pin and afterwards drill the complete measured length with the graduated drill bit.



Important:

Keep the drill aligned with the axis and do not jam.

Check the correct position of the guide pin by fluoroscopy with the C-arm in the a-p and axial plane. For optimum placement the guide pin should only be used once.

If the guide pin appears to be bent in the X-ray, there is a danger of guide pin damage when the graduated drill is applied. Therefore it is recommended for these cases to proceed with antirotational pin placement first. The graduated drill is applied subsequently after removal of the guide pin. Make sure that there is as little soft tissue pressure as possible on the tissue protection sleeve so that it will not change its position.

Aesculap® Targon® PFT

Surgical Technique

Measuring the Length of the TeleScrew

8

- KH534P – Length gauge green
- KH536R – Graduated drill bit

There are two different options for TeleScrew length determination:

1. If the optional lateral access drill (KH554R) is used: Slipping the length gauge over the guide pin, measuring against the lateral access drill. As the lateral access drill has defined contact with the nail, this measurement is very accurate.

2. Direct measurement with the graduated drill: Apply the graduated drill KH536R with the depth stop KH535R mounted and locked at the shortest length of 75 mm in order to open the cortex (see chapter 10). Then use the graduated drill KH536R under fluoroscopic control with the depth stop KH535R mounted loosely as described in chapter 11. When the desired position is reached, the depth stop can be advanced until nail contact. The length indicated on the graduated drill corresponds to the TeleScrew length needed.

Regardless of the measuring option used, we recommend usage of a TeleScrew of the measured length or shorter as described in chapter 9.

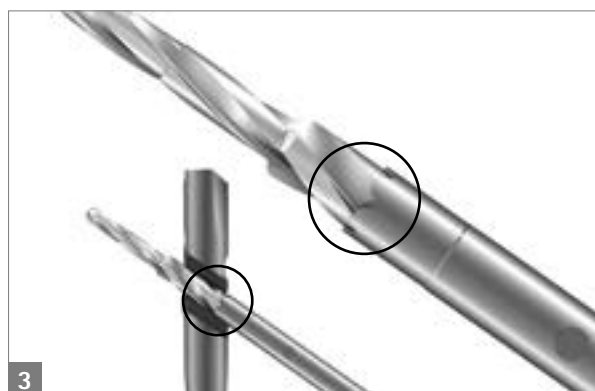

9

Measuring the Length of the TeleScrew

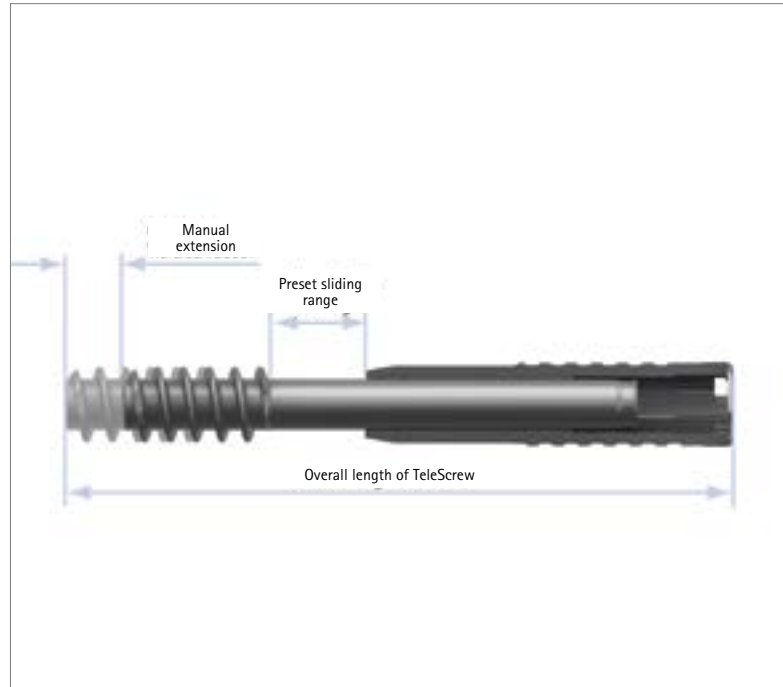

The length of the TeleScrew

Example 1:

Length measured 106 mm
Overall length of TeleScrew 105 mm

Example 2:

Length measured 108 mm
Overall length of TeleScrew 105 mm

Example 3:

Length measured 110 mm
Overall length of TeleScrew 110 mm

Depending on its overall length, the TeleScrew can slide over a distance of 15 mm or 20 mm. This distance depends on the preset sliding distance plus the manual extension.

Always select a TeleScrew that is identical (example 3) with the length measured or shorter (examples 1+2).

Overall length TeleScrew / mm	Sliding range
75	15
80	15
85	15
90	20
95	20
100	20
105	20
110	20
115	20
120	20

Aesculap® Targon® PFT

Surgical Technique

Mounting the Graduated Drill Bit with Stop

10

- KH536R – Graduated drill bit
- KH535R – Drill guide with stop

Set the stop of the graduated drill bit to the length of the TeleScrew selected.

Always employ the stop of the graduated drill bit in order to avoid drilling too far.

The coloured fields (Fig. 1) on the graduated drill indicate the approximate depths relating to the respective nail type (CCD angle).

Important:

If the guide pin is bent by the trabeculae of the femoral head (cranial deviation), set graduated drill bit to the shortest length and drill as far as the stop. Initially leave the drill bit and guide pin in this position until the antirotation pin is implanted. Then remove the guide pin and, without it, advance the graduated drill bit to the measured length.

Caution:

As this happens, the central canal of the reamer fills with bone material. This should be removed immediately after use.



1 When viewed in the working direction turn left to lock.

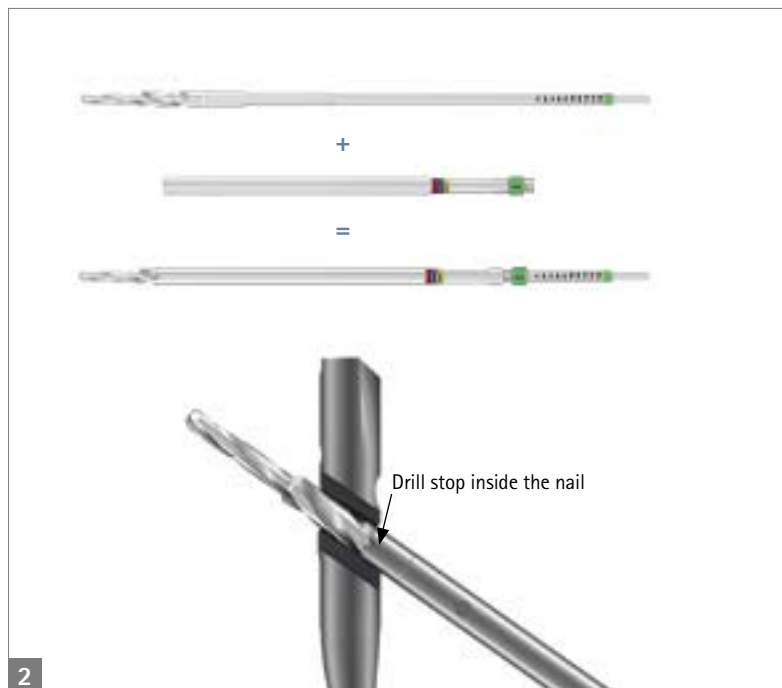

2

Drilling the Hole for the TeleScrew

11

Introduce the graduated drill bit into the large tissue protection sleeve over the guide pin and drill through the lateral cortical wall of the femur until the nail is met (Fig. 1). Do not force the graduated drill bit but stop as soon as it hits the nail. Once the stop is reached, check the drill depth (position of the tip of the drill bit) with the C-arm. If necessary, re-adjust the drill stop so that the tip of the drill bit comes to within 5 mm of the femoral head cortical bone. Re-calculate the TeleScrew length accordingly. The coloured fields on the graduated drill bit do not act as stops – the stop is on the nail itself. They are simply a rough indication of depth depending on the type of nail selected. During drilling, make sure to maintain the axial direction and not to jam the drill bit. If the guide pin was displaced cranially by the trabeculae of the femoral head, do not fully advance the graduated drill bit. In this case, pull back the guide pin after the length measurement but still leave it inserted at least within the entry cortical bone and the nail. Then complete the drilling phase.

Alternatively:

Quicklock T-handle KH458R

Alternatively, the lateral cortical wall of the femur may be drilled by hand. To this end, mount the graduated drill bit in the Quicklock T-handle (Fig. 2).

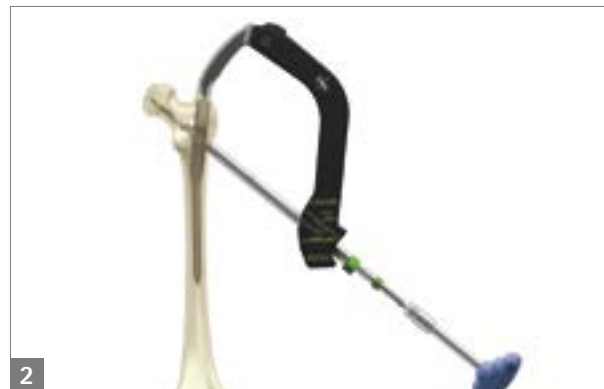
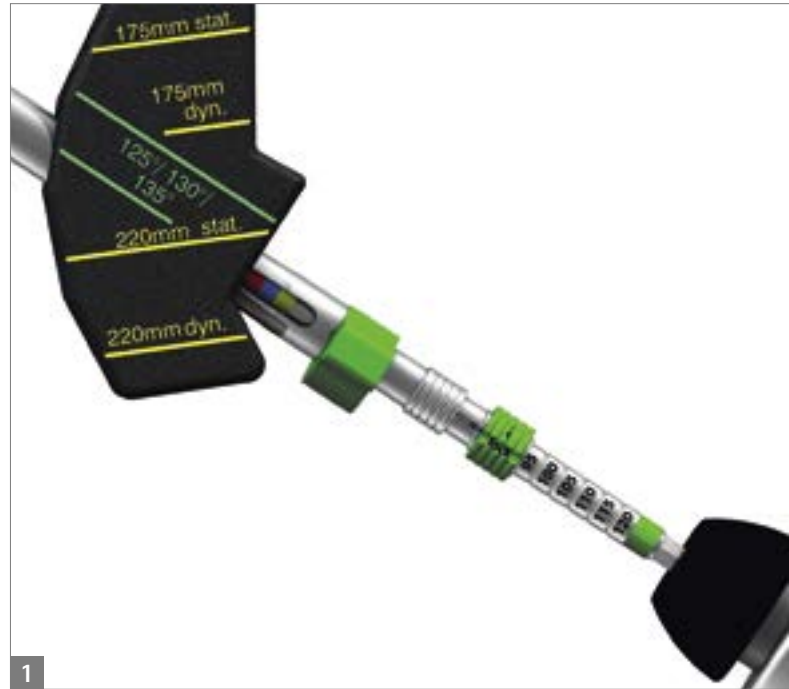

Important:

For better stability leave the drill bit within the targeting device.

Note:

If the guide pin displays severe deviation:

1. Open the drill bit and pull back to the shortest length possible, leaving the drill bit still blocked.
2. Insert the antirotation pin.
3. Remove the guide pin.
4. Reset the drill bit to the overall length measured and complete drilling.

Aesculap® Targon® PFT

Surgical Technique

Countersinking the Antirotation Pin

12

- KH538R – Tissue protector small
- KH539R – Obturator small
- KH540R – Countersink small

Make a stab incision, advance the small tissue protector with the small obturator until it contacts the cortical bone and by turning lock it in the hole of the targeting device.

Remove obturator.

Introduce the small countersink through the tissue protection sleeve and advance by high-speed drilling through the lateral cortical wall of the femur until contact is made with the nail.

Make sure to keep the axial direction and not to exert pressure, which otherwise could result in malpositioning.

The green marker at the countersink is not a stop but simply indicates the rough depth.

Remove countersink.



Drilling the Hole for the Antirotation Pin

13



- KH549R – Drill sleeve small
- KH541R – Drill bit \varnothing 4.1 mm

Introduce the small drill sleeve through the tissue protector.

With the 4.1 mm drill bit and under fluoroscopy with the C-arm, drill to the transition zone between femoral head and femoral neck.

The tip of the guide pin should not be closer than 20 mm to the subchondral bone of that. The tip of the pin should be at the level of a horizontal line drawn from the tip of the graduated drill.

Read off the length of the antirotation pin from the scale on the drill bit.

Make sure that the sleeves are in direct contact with the cortical wall of the femur in order to ensure correct length measurement.

Aesculap® Targon® PFT

Surgical Technique

Inserting the Antirotation Pin

14

■ KH542R – Graduated screwdriver

Remove the small drill sleeve.

With the graduated screwdriver, introduce the selected antirotation pin through the tissue protector. Tighten the antirotation pin with the correct torque (4 Nm).

A black ring on the screwdriver marks the depth at which the thread of the antirotation pin engages with the counter-thread in the nail.

Caution:

The graduated screwdriver KH542R only indicates the torque but does not limit it.



**Optional:
Lag Screw Tapping**

15



- KH543R – Tap for TeleScrew
- KH458R – Quicklock T-Handle

In very hard bone, one option would be to tap the thread for the TeleScrew manually.

Remove guide pin and graduated drill bit.

Connect the tap to the T-handle and introduce it through the tissue protection sleeve over the guide pin. The cutting depth of the tap is clearly limited by the end of the drill canal. Check the cutting depth with the C-arm.

After tapping, remove tap.

Aesculap® Targon® PFT

Surgical Technique

Inserting and extending the TeleScrew
by hand to the maximum sliding length

16

- KH542R – Graduated screwdriver for inserting and tightening the TeleScrews (Fig. 1+2)
- KH544R – Screwdriver \square 4.5 for final length adjustment of TeleScrew length

Remove graduated drill bit and guide pin.

Insertion

For insertion, the TeleScrew is connected with the green graduated screwdriver. First connect the inner screw and then the outer sleeve. Then insert the TeleScrew through the tissue protection sleeve and tighten to the correct torque (8 Nm).

Extension

The TeleScrew is extended by hand with the yellow 4.5 mm screwdriver (about two turns). The scale on the screwdriver indicates the extension in millimeters.

Under a-p and axial fluoroscopy, the length of the TeleScrew is set so that its tip has optimum grip in the end of the drill hole.

Caution:

The graduated screwdriver KH542R only indicates the torque but does not limit it.

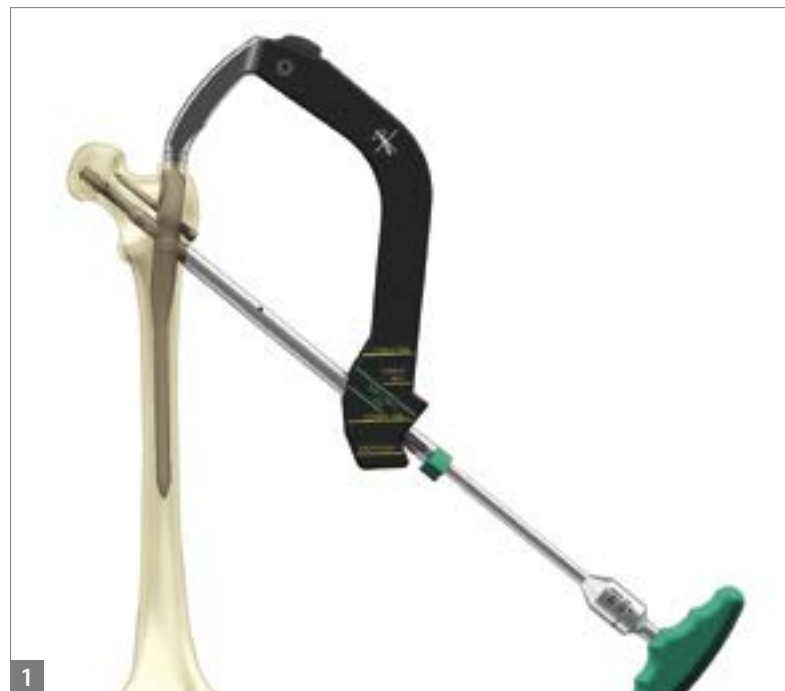

Distal Locking

Inserting the Small Tissue Protector

17



- KH538R – Tissue protector small
- KH539R – Obturator small

Mark the skin with the small tissue protection sleeve over the planned hole which corresponds to the chosen type of locking (static or dynamic) and the nail length (175 or 220 mm).

Incise the skin and split the fascia and vastus lateralis muscle.

Ensure that the tissue split, precisely in the direction of the drill sleeve, is long enough to avoid pressure from the fascia on the drill sleeve, which could result in malpositioning of the drill hole.

Advance the tissue protector and obturator until they contact the bone. Remove obturator.

Aesculap® Targon® PFT

Surgical Technique

Countersinking the Lateral Cortical Wall

18



■ KH540R – Countersink small

Without force, introduce the small countersink into the tissue protector and high-speed drill until it contacts the lateral cortical wall of the femur; then countersink to a depth of about 1-2 mm.

The yellow marker gives a rough indication of the depth of insertion of the countersink.

Caution:

At all costs, do not countersink through the entire cortical wall.

Drilling

19

- KH549R – Drill sleeve small
- KH541R – Drill bit \varnothing 4.1 mm

Introduce the small drill sleeve into the tissue protector and by turning lock it into the bow of the targeting device.

Drill through the lateral and medial cortical wall of the femur with the 4.1 mm drill bit (Fig. 1).

The length of the locking screw is read off at the scale on the drill bit (Fig. 2).

Remove drill sleeve.



Aesculap® Targon® PFT

Surgical Technique

Locking

20



■ KH544R – Screwdriver \square 4.5

Attach the screw selected to the retaining screwdriver. Push the screw towards the handle and set the screwdriver to 'lock', which will fasten the screw.

Insert the locking screw with the screwdriver through the tissue protector.

Set the screwdriver to 'unlock' to unfasten the locking screw.

Remove tissue protector.

Inserting the Cap Screw

21

- KH548R – Nail adapter wrench
- KH458R – Quicklock T-handle
- KH544R – Screwdriver \square 4.5

Remove the bow of the targeting device with the nail adapter wrench and the Quicklock T-handle (Fig. 1).

Attach the cap screw to the retaining screwdriver and screw into the end of the nail (Fig. 2).

Check and document the implant position by fluoroscopy with the C-arm.



Aesculap® Targon® PFT

Surgical Technique

Implant Removal

A – TeleScrew

22

- KH458R – Quicklock T-Handle
- KH546R – Screw extractor for TeleScrew sleeve
- KH545R – Reinforced screw extractor for TeleScrew

- 1 Connect reinforced screw extractor for TeleScrew to the quicklock T-handle.
- 2 Insert the blue quicklock T-handle for the TeleScrew through the red screw extractor for the TeleScrew sleeve.
- 3 After soft tissue opening, under C-arm fluoroscopy advance both the T-handle and the screw extractor together into the TeleScrew through the same access as for implantation, until it engages in the TeleScrew. Now the TeleScrew can be screwed out of the thread of the nail and out of the bone by turning both handles at the same time.

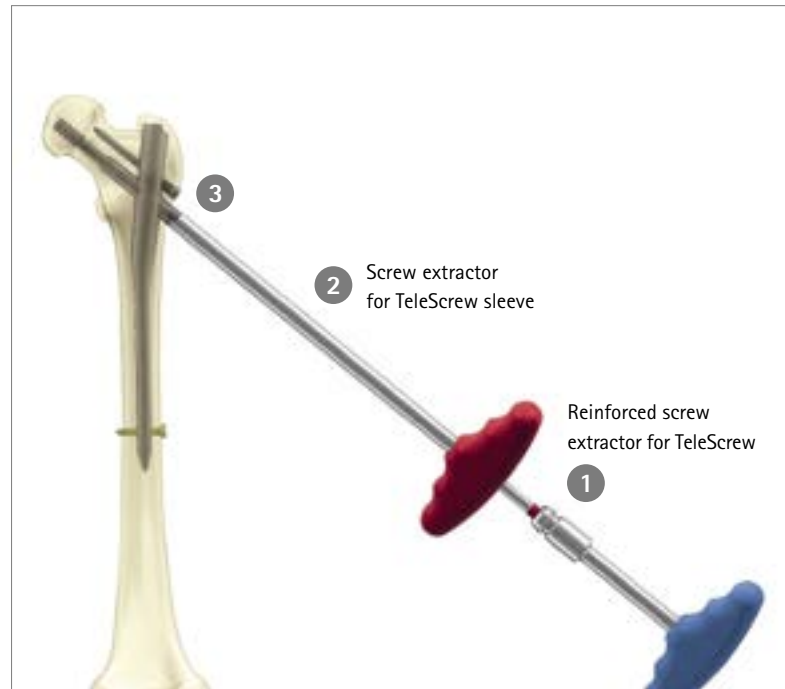

Caution:

Before the extraction of the TeleScrew, carefully clean the nail from any ingrown tissue. Otherwise this might damage the instruments and the implant during extraction.

Make sure that the TeleScrew extractor not only engages with the screw but also the sleeve of the TeleScrew so that the implant may be removed as one unit.

B – Antirotation Pin



- KH545R – Reinforced screw extractor for TeleScrew, antirotation pin and locking screw.
- KKH458R – Quicklock T-Handle

Mount the extractor to the T-handle.

Advance the extractor through the soft tissue under fluoroscopy with the C-arm until it engages with the antirotation pin.

Unscrew the antirotation pin from the thread of the nail and remove it.

Caution:

Before the extraction of the antirotation pin, carefully clean the nail from any ingrown tissue. Otherwise this might damage the instruments and implant during extraction.

Aesculap® Targon® PFT

Surgical Technique

C – Cap Screw

- KH544R – Screwdriver
- KH542R – Extraction adapter nail

Incise the old scar of the proximal approach. Divide the subcutaneous tissue, fascia lata and the insertion of the middle gluteus muscle in the direction of the upper opening in the nail.

Remove the cap screw with the retaining screwdriver.

Screw the adapter into the proximal end of the nail.



D – Distal Unlocking

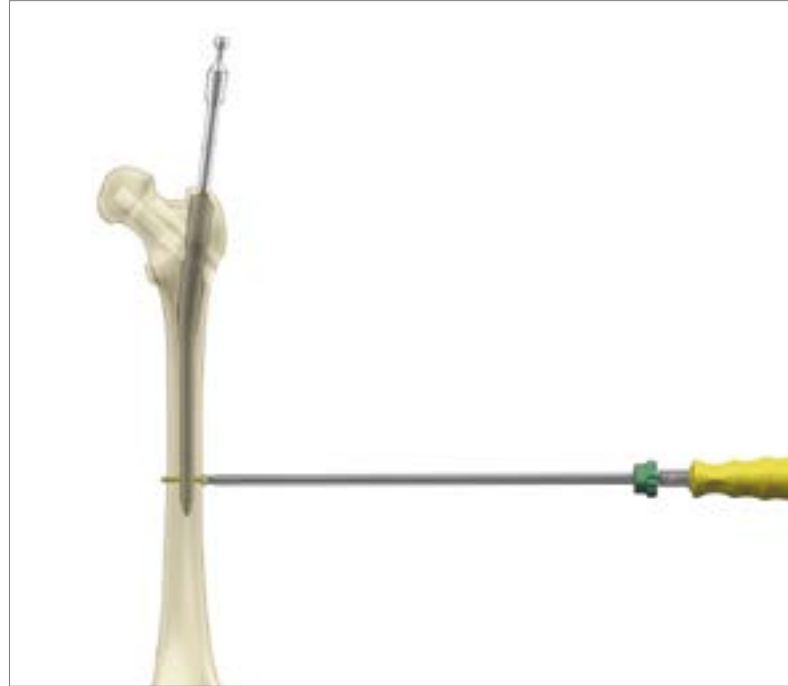

- KH544R – Screwdriver \square 4.5

alternatively:

- KH545R – Reinforced extractor
- KH458R – Quicklock T-Handle

Make a stab incision in the area of the old scar and remove the distal locking screw with the retaining screwdriver or the T-handle combined with reinforced screw retractor.

Aesculap® Targon® PFT

Surgical Technique

E – Nail

- KH458R – Quicklock T-Handle
- KH492R – Extraction adapter nail
- KH490R – Extractor
- KH460R – Hammer

Where the nail is severely overgrown with bone, advance the guide pin through the bone overgrowth into the nail opening with the aid of the C-arm.

Then fit the tissue protection sleeve and carefully drill the bone through this with the corer as far as the proximal end of the nail.

1. Remove the closing screw
2. Tightly screw in the extraction adapter
3. Connect the extractor with the adapter and screw tight the support sleeve
4. Remove the locking screws
5. Connect the extractor to the T-handle
6. Knock out the nail with the connected extractor and the combi-hammer

Note:

We recommend that the special instrument set be available whenever an extraction is planned. Leasing set no. O-0011 and O-0012 can be ordered through the leasing service under +49 7461 95-2019.

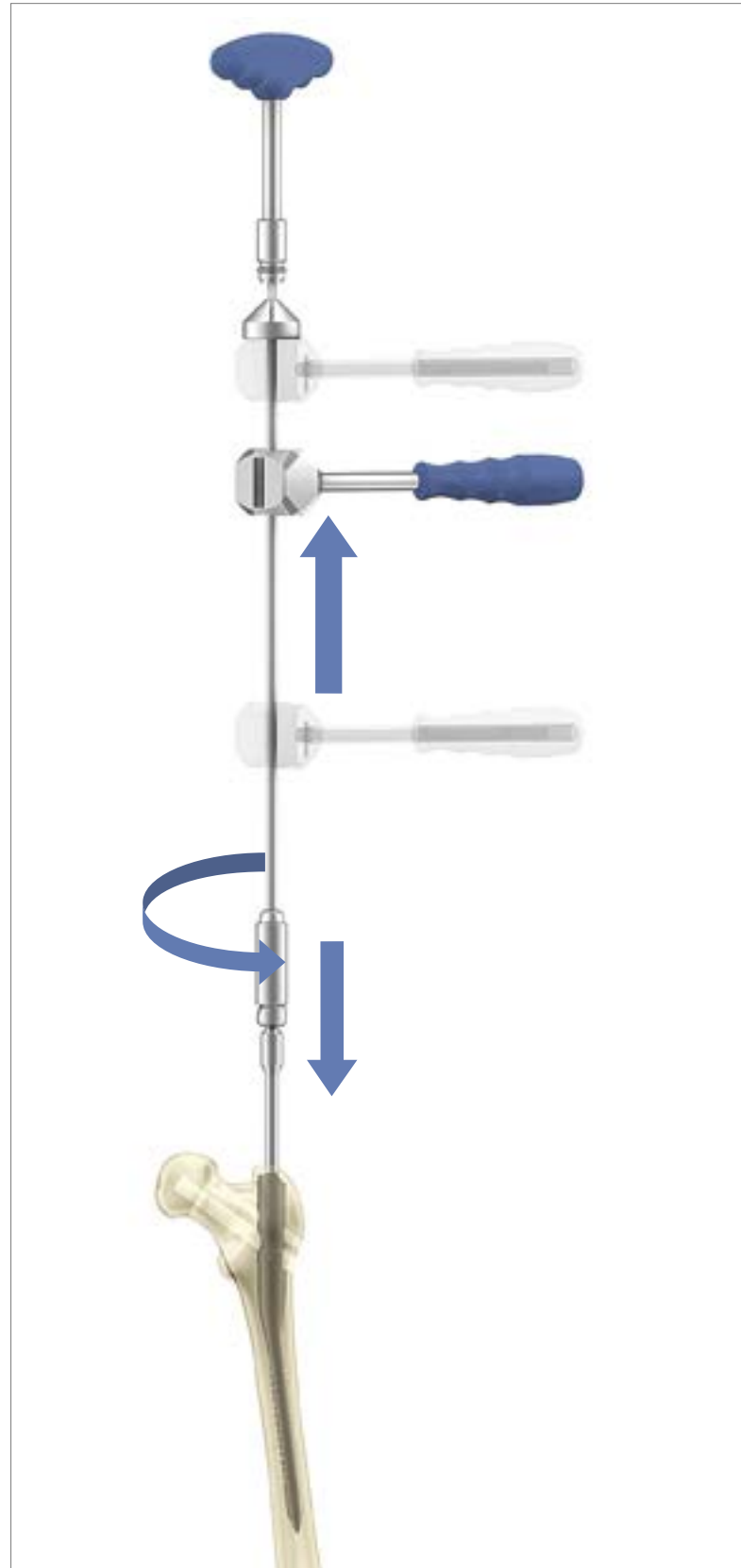

Case Examples

23



Instruments – Overview

KH510 Basic Instruments Targon® PFT – Tray 1

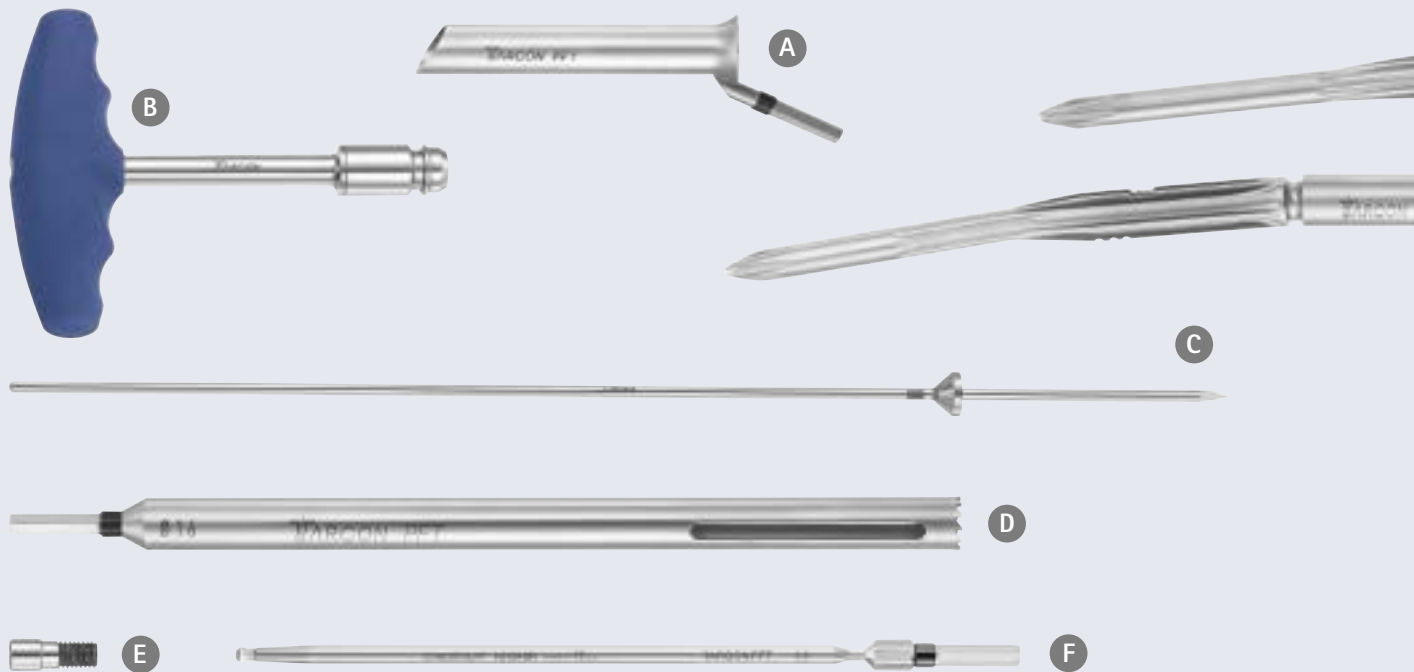

	Article no.	Description
A	KH526R	Tissue protector
B	KH458R	Quicklock T-handle
C	KH525R	Guide pin with stop
D	KH524R	Corer
E	KH450R	Nail adapter screw
F	KH548R	Nail adapter wrench
G	KH528R	Contoured reamer for Targon® PFT 220 mm
H	KH529R	Contoured reamer Targon® PFT, short and long
I	KH520P	Targeting device



Color Coding – Organization of the Instrument Tray

- Approach
- Proximal Locking
- Distal Locking
- General Instruments
- Explantation

Instruments – Overview

KH510 Basic Instruments Targon® PFT – Tray 2



	Article no.	Description
A	KH531R	Targon® PFT obturator for tissue protector, large
B	KH532R	Targon® PFT tissue protector, large
C	KH537R	Targon® PFT drill sleeve for guide pin
D	KH534P	Targon® PFT length gauge
E	KH536R	Targon® PFT graduated drill bit
F	KH535R	Targon® PFT drill stop for KH536R
G	KH539R	Targon® PFT obturator, small
H	KH538R	Targon® PFT tissue protector, small
I	KH540R	Targon® PFT countersink, small
J	KH549R	Targon® PFT drill sleeve, small
K	KH541R	Targon® PFT drill bit ø 4.1 mm
L	KH542R	Targon® PFT graduated screwdriver
M	KH544R	Targon® PFT screwdriver 4.5



Color Coding – Organization of the Instrument Tray

- Approach
- Proximal Locking
- Distal Locking
- General Instruments
- Explantation

Instruments – Overview

Optional instruments Targon® PFT (Tray)

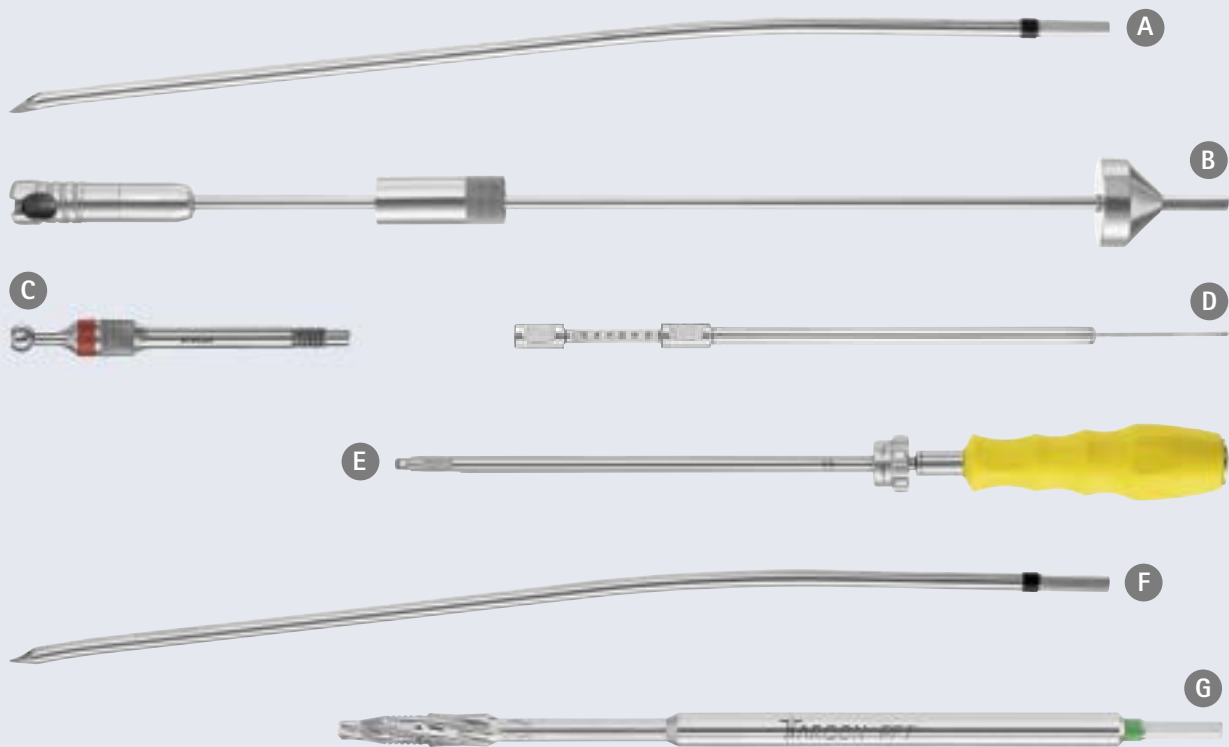

	Article no.	Description
A	KH464R	Reduction instrument (sharp)
B	KH490R	Extractor
C	KH492R	Extraction adapter for nail
D	KH473R	Screw length gauge 85 mm for free hand locking
E	KT236R	Retaining screwdriver \varnothing 4.5
F	KH463R	Reduction instrument
G	KH554R	Cannulated access drill
H	KH527R	Broach \varnothing 17.1 mm
I	KH543R	Tap for TeleScrew
J	KH546R	Screw extractor for TeleScrew
K	KH545R	Reinforced screw extractor for TeleScrew
L	KH547R	Free hand drill bit \varnothing 4.1 mm
M	KH478P	Length gauge
N	KH460R	Hammer

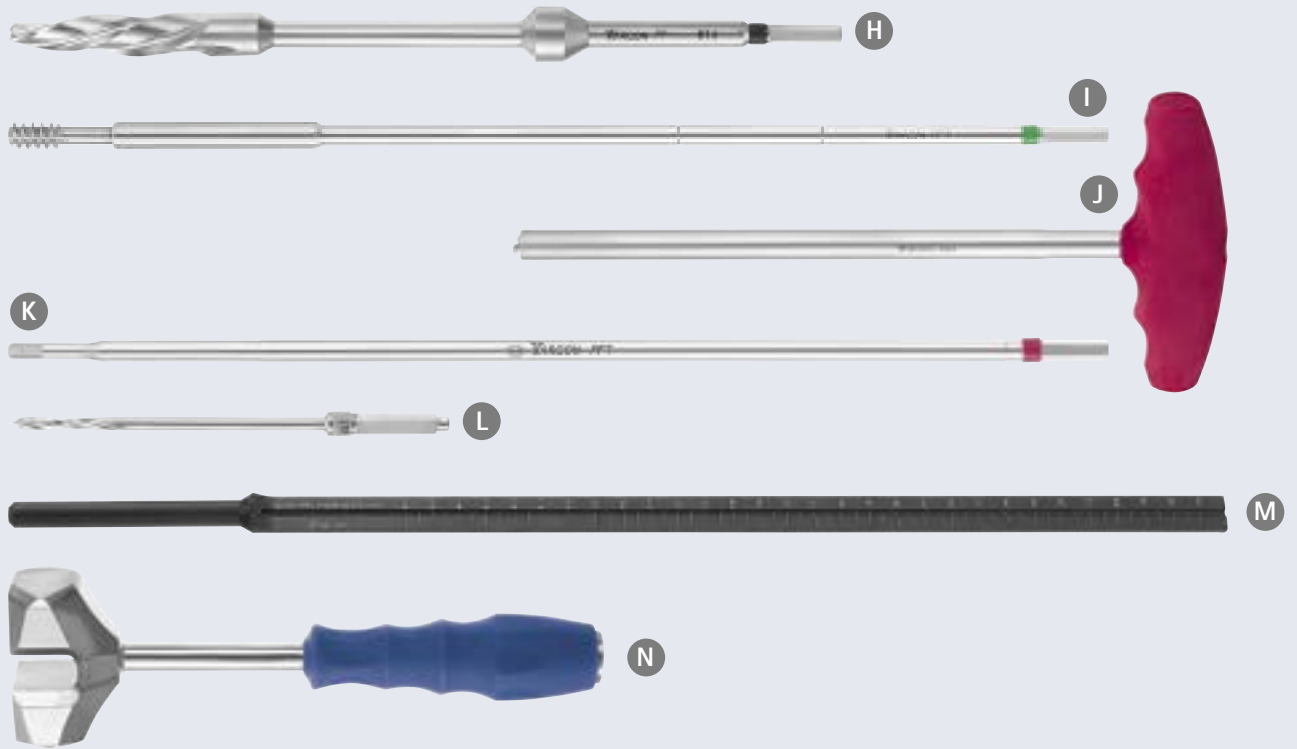

Color Coding – Organization of the Instrument Tray

- Approach
- Proximal Locking
- Distal Locking
- General Instruments
- Explantation

Instruments and Implants

KH510 Basic Instruments Targon® PFT – Tray 1

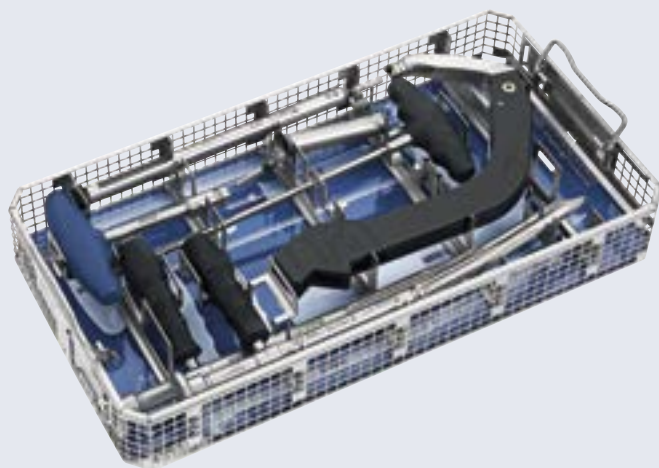

Article no.	Description	Number
KH521	X-ray template Targon® PFT, standard	1
KH522	X-ray template Targon® PFT, short	1
KH523	X-ray template Targon® PFT, long	1
KH526R	Tissue protector	1
KH458R	Quicklock T-handle	1
KH525R	Guide pin with stop	1
KH524R	Corer	1
KH528R	Contoured reamer Targon® PFT, 220 mm	1
KH529R	Contoured reamer Targon® PFT short and long	1
KH520P	Targeting device (black)	1
KH450R	Nail adapter screw	1
KH548R	Nail adapter wrench	1
KH511R	Tray container with tray 1	1
TE935	Graphics template 1	1
JH217R	Lid for tray container	1
JG787B	Container label	1
TA012039	Instructions for use	1

Recommended container:
JK444 bottom, height 187 mm,
JP002 lid

Tray 2

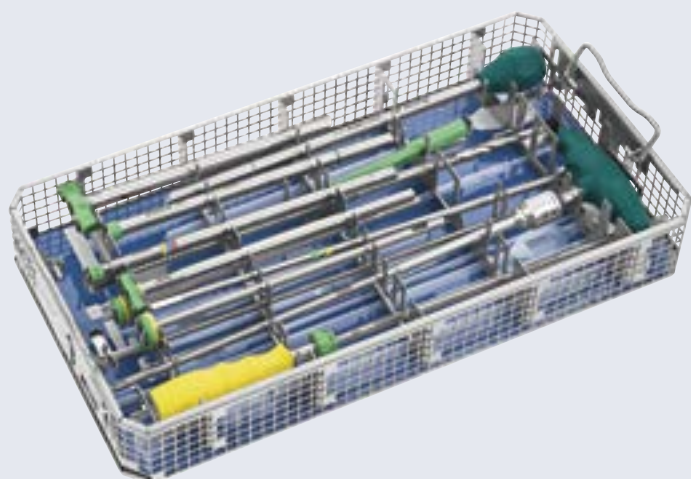

Article no.	Description	Number
KH531R	Targon® PFT obturator for tissue protector, large	1
KH532R	Targon® PFT tissue protector, large	1
KH537R	Targon® PFT drill sleeve for guide pin	1
KH534P	Targon® PFT length gauge	1
KH536R	Targon® PFT graduated drill bit	1
KH535R	Targon® PFT drill stop for KH536R	1
KH539R	Targon® PFT obturator small	1
KH538R	Targon® PFT tissue protector, small	1
KH540R	Targon® PFT countersink, small	1
KH549R	Targon® PFT drill sleeve, small	1
KH541R	Targon® PFT drill bit ø 4.1 mm	1
KH542R	Targon® PFT graduated screwdriver	1
KH544R	Targon® PFT screwdriver \varnothing 4.5	1
KH512R	Targon® PFT tray container with tray 2	1
TE936	Graphics template 2	1
KH668S	Guide pin (2 pcs. / pkg.)	1

Instruments and Implants

Optional instruments Targon® PFT (to be ordered individually)

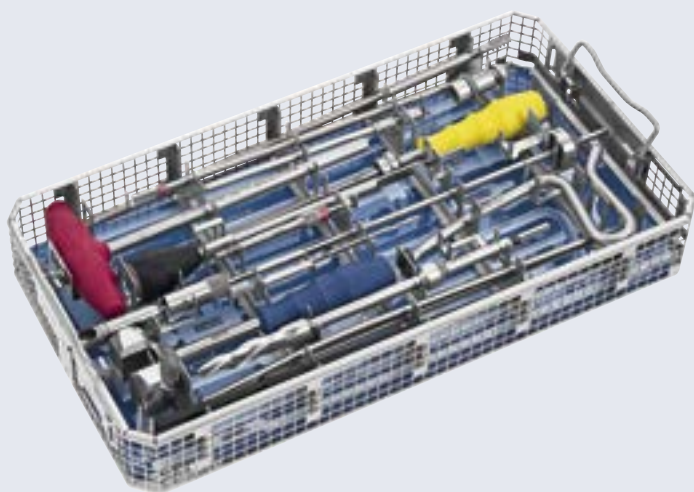

Article no.	Description	Number
KH317R	Broach	1
KH464R	Reduction instrument (sharp)	1
KH490R	Extractor	1
KH491R	Extraction adapter targeting device	1
KH492R	Extraction adapter nail	1
KH473R	Screw length gauge 85 mm for free hand locking	1
KT236R	Retaining screwdriver \varnothing 4.5	1
KH463R	Reduction instrument	1
KH527R	Broach \varnothing 17.1 mm	1
KH543R	Tap for TeleScrew	1
KH546R	Screw extractor for TeleScrew	1
KH545R	Reinforced screw extractor for TeleScrew	1
KH547R	Free hand drill bit \varnothing 4.1 mm	1
KH554R	Cannulated Access drill	1
KH478P	Length gauge	1
KH460R	Hammer	1

GB413R or GB414R	Motor connection	1
KH513R	Tray container with tray 1	1
TE937	Graphics template 1	1
JH217R	Lid for tray container	1

Recommended container:
JK440 bottom, height 90 mm,
JP002 lid

- 1 KH668S Guide pin, length 440 mm,
diameter 3.0 mm, sterile (2 pcs.)
- 1 KH319R Universal T-handle, contained in
the intramedullary drill set GE661
- 1 GE663S Guide pin 2.5 mm, length 800 mm,
olive tip diameter 3.2 mm

Ordering information – Implants (packed sterile)



Standard Nail Length 220 mm

Angle	ø	Article no.
125°	10 mm	KF022T
	12 mm	KF032T
130°	10 mm	KF023T
	12 mm	KF033T
135°	10 mm	KF024T
	12 mm	KF034T

Instructions for use
TA-No. 010481
Targon® locking nail systems
in sterile packaging

Instruments and Implants

Ordering information – Implants (packed sterile)



Short nail length 175 mm

Angle	ø	Article no.
125°	10 mm	KF002T
	12 mm	KF012T
130°	10 mm	KF003T
	12 mm	KF013T
135°	10 mm	KF004T
	12 mm	KF014T

Instructions for use
TA-No. 010481
Targon® locking nail systems
in sterile packaging

Ordering Information – Implants (packed sterile)



Long nail / right 125°, ø 10 mm

Length	Article no.
260 mm	KF151T
300 mm	KF152T
340 mm	KF153T
380 mm	KF154T
420 mm	KF155T
460 mm	KF156T

Long nail / left 125°, ø 10 mm

Length	Article no.
260 mm	KF141T
300 mm	KF142T
340 mm	KF143T
380 mm	KF144T
420 mm	KF145T
460 mm	KF146T

Long nail / right 130°, ø 10 mm

Length	Article no.
260 mm	KF171T
300 mm	KF172T
340 mm	KF173T
380 mm	KF174T
420 mm	KF175T
460 mm	KF176T

Long nail / left 130°, ø 10 mm

Length	Article no.
260 mm	KF161T
300 mm	KF162T
340 mm	KF163T
380 mm	KF164T
420 mm	KF165T
460 mm	KF166T

Long nail / right 130°, ø 12 mm

Length	Article no.
260 mm	KF271T
300 mm	KF272T
340 mm	KF273T
380 mm	KF274T
420 mm	KF275T
460 mm	KF276T

Long nail / left 130°, ø 12 mm

Length	Article no.
260 mm	KF261T
300 mm	KF262T
340 mm	KF263T
380 mm	KF264T
420 mm	KF265T
460 mm	KF266T

Instructions for use
TA-No. 010481
Targon® locking nail systems
in sterile packaging

Instruments and Implants

Ordering information – Implants (packed sterile)



TeleScrew

Article no.	Description	Total length
KF221T	Targon® PFT TeleScrew 70 + 5 mm	75 mm
KF222T	Targon® PFT TeleScrew 75 + 5 mm	80 mm
KF223T	Targon® PFT TeleScrew 80 + 5 mm	85 mm
KF224T	Targon® PFT TeleScrew 85 + 5 mm	90 mm
KF225T	Targon® PFT TeleScrew 90 + 5 mm	95 mm
KF226T	Targon® PFT TeleScrew 95 + 5 mm	100 mm
KF227T	Targon® PFT TeleScrew 100 + 5 mm	105 mm
KF228T	Targon® PFT TeleScrew 105 + 5 mm	110 mm
KF229T	Targon® PFT TeleScrew 110 + 5 mm	115 mm
KF230T	Targon® PFT TeleScrew 115 + 5 mm	120 mm



Antirotation pin

Length	Article no.
55 mm	KF202T
60 mm	KF203T
65 mm	KF204T
70 mm	KF205T
75 mm	KF206T
80 mm	KF207T
85 mm	KF208T
90 mm	KF209T
95 mm	KF210T
100 mm	KF211T

Locking screws
ø 4.5 mm



Length	Article no.
20 mm	KB320TS
24 mm	KB324TS
28 mm	KB328TS
32 mm	KB332TS
36 mm	KB336TS
40 mm	KB340TS
44 mm	KB344TS
48 mm	KB348TS
52 mm	KB352TS
56 mm	KB356TS
60 mm	KB360TS
64 mm	KB364TS
68 mm	KB368TS
72 mm	KB372TS
76 mm	KB376TS
80 mm	KB380TS

Cap screw



Length	Article no.
-	KB200TS

Aesculap® Targon® PFT

Operative procedure

Opening up



Preparing the nail bed



Mounting and inserting the nail



Fine adjustment depth and axial



Opening up the lateral cortical wall



Positioning the guide pin
Measuring the length
of the TeleScrew
against drill sleeve



Drilling for TeleScrew
drill bit remains in place



Countersinking the
antirotation pin



Drilling for
antirotation pin





Inserting the antirotatin pin



Tapping (optional), inserting and extending the TeleScrew



Distal locking: Countersinking, drilling, locking

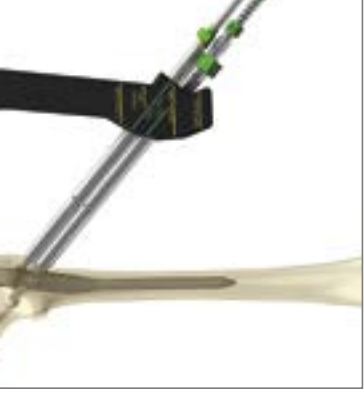

Inserting the cap screw

